

AC25 Service Manual

Table of Contents

Specifications

Installation

Start Up

Freezing Cycle

Harvest Cycle

Component Description

Refrigerant Charge

Adjustment

Replacement

Cleaning

Sanitizing

Service Diagnosis

SPECIFICATIONS

AC25

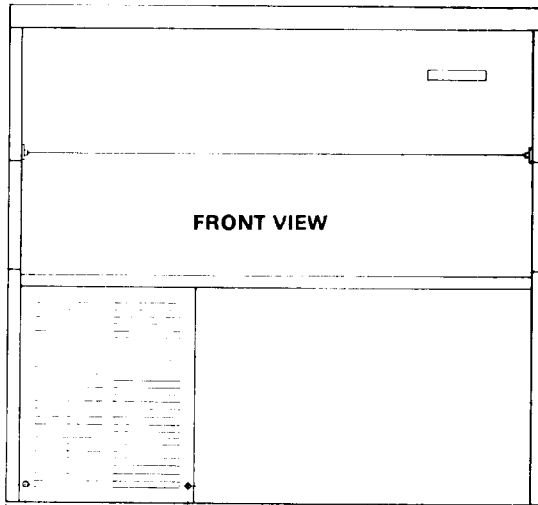

FRONT VIEW

15.2 CM
6 IN. RECOMMENDED FOR UTILITY CONNECTIONS

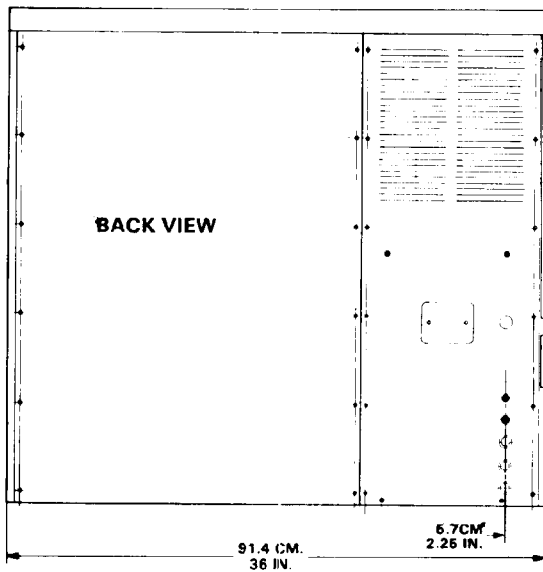

BACK VIEW

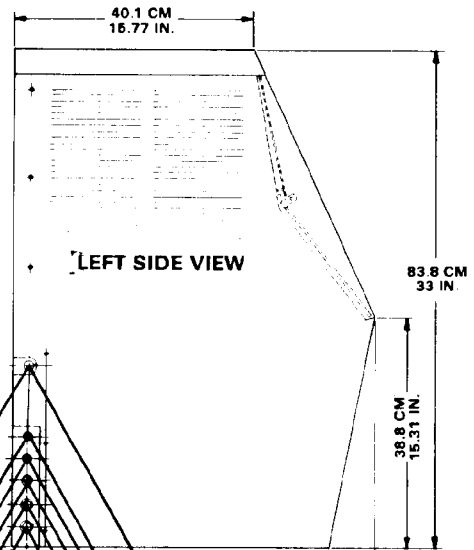

LEFT SIDE VIEW

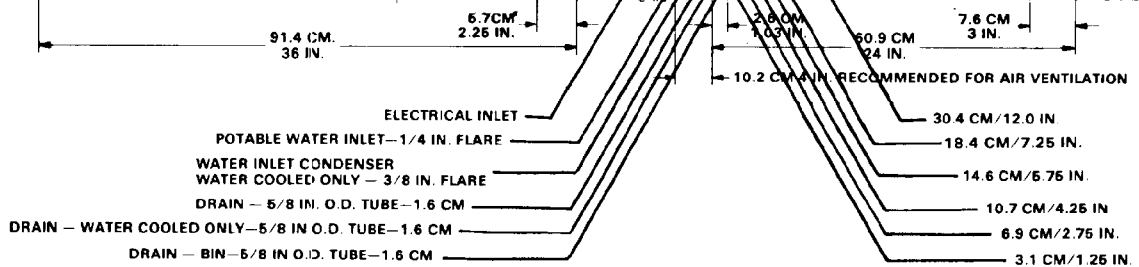

SPECIFICATIONS (Cont'd)

MODEL AC25

Bin Storage: 140 lbs.*

Air-Cooled: Model AC25A-1A



Water-Cooled: Model AC25W-1A

Electrical: 115/60/1

Est. Ship. Wt.: 350 lbs.

NAME PLATE

MODEL NUMBER			
SERIAL NUMBER			
A.C. SUPPLY VOLTAGE			
MINIMUM CIRCUIT AMPACITY		WIRES	
MAXIMUM FUSE SIZE *		HERTZ	
HEATER WATTS		PHASE	
REFRIGERANT	CHARGE	OZ	
MOTORS	VOLTS	R.L.A./F.L.A.	W/H.P. L.R.A.
COMPRESSOR			
FAN			
DRIVE			
OTHER			
DESIGN PRESSURE	LOW	HIGH	
* OR HACR TYPE CIRCUIT BREAKER			

SCOTSMAN

Scotsman Ice Systems are designed and manufactured with the highest regard for safety and performance. They meet or exceed the standards of U.L., N.S.F., and C.S.A. Scotsman assumes no liability of any kind for products manufactured by Scotsman that have been altered in any way, including the use of any parts and/or components not specifically approved by Scotsman.

Scotsman reserves the right to make design changes and/or improvements at any time. Specifications and designs are subject to change without notice.

FRONT SERVICE ACCESS PANEL

LEG KIT

KLP2E - 6-inch metal legs, Black Enamel

KLP2S - 6-inch metal legs, Nickel Plated

SEE NAMEPLATE, shown at left, for electrical and refrigeration specifications. NAMEPLATE located on rear service panel, near left rear corner of the cabinet.

Remove Lower Left Front Panel to locate the Model/Serial Number plate, shown below, on the front left corner of the Base Assembly.

SERIAL NUMBER PLATE

MODEL NUMBER			
SERIAL NUMBER			
VOLTS/HERTZ/PHASE			
MAXIMUM FUSE SIZE			
REFRIGERANT	CHARGE	OZ	

*Storage based on 90-percent of total volume x 34 lbs. average density of ice. A.R.I. Standard.



This icemaker has been engineered to our own rigid safety and performance standards. The National Sanitation Foundation (NSF) seal, signifies that it is listed with the NSF and that it complies with the materials and construction standards of the NSF. In addition, the Underwriters Laboratories, Inc., (UL) Listing Mark and the Canadian Standards Association (CSA) Monogram, both signify that its construction and design have been inspected and tested by them. NSF, UL and CSA inspectors also periodically examine production icemakers at the factory, to assure continued compliance.

To retain the safety and performance built into this icemaker, it is important that installation and maintenance be conducted in the manner outlined in this manual.

SECTION I

GENERAL INFORMATION & INSTALLATION

I. INTRODUCTION

This manual provides specifications and the step-by-step procedures for the installation start-up, operation, and the maintenance and cleaning for the SCOTSMAN Model AC25 Cuber.

The Model AC25 Cubers are quality designed, engineered, and constructed, and thoroughly tested icemaking and ice storage systems, providing the utmost in flexibility to fit the needs of a particular user. Separate sections detail more specifically: General Information & Installation; Start Up Operation; Principles of Operation; Adjustment and Removal and Replacement Procedures; Maintenance and Cleaning Instructions; Service Diagnosis; Wiring Diagrams; and, the Illustrated Assemblies and Parts Lists.

One of the outstanding features of this series of Cubers, is the easy access for service. With the Bin Door, the top Front Panel, and the Left Side Panel removed, access can be gained to the refrigeration systems for on-the-spot repair.

DESCRIPTION

An attractive compact cabinet of textured metal with a Sandelwood enamel finish, a woodgrain upper front panel and a bin access door. Also, an optional stainless steel cabinet finish is available. Both cabinets have up-to-date styling, and easily removable front panels for easy access to electrical and mechanical components.

SEALED REFRIGERATION SYSTEM

To provide quiet efficient operation of the Ice-maker, the Compressor motor is internally spring-mounted. The Compressor motor is covered by a five year parts warranty.

SELF-CONTAINED STORAGE BIN

These Cubers store their own ice supply in an ice storage bin inside an insulated cabinet.

OVERALL DIMENSIONS

The overall dimensions of the Cuber depth, height, etc., allows the Cuber to be installed in harmony with the existing counter equipment.

II. UNPACKING AND INSPECTION

1. Call your authorized SCOTSMAN Distributor or Dealer, for proper installation. He's listed under ICE MAKING EQUIPMENT and MACHINERY in the yellow pages of the telephone book.
2. Visually inspect the exterior of the shipping container and skid and any severe damage noted, should be reported to the delivering

carrier; and, a concealed damage claim filed subject to internal inspection, with carrier representative present.

3. BEFORE removal of any panels or packing, carefully lay the Cuber on its back and remove the shipping bolts and the shipping base or skid.
4. Remove screws and shipping tape, and the Bin Door and top Front Panel from the cabinet, and inspect for any concealed damage claims, as stated in step 2 above.
5. Remove all internal support packing, tape and wires in machinery compartment.
6. Check that refrigerant lines do not rub or touch lines or other surfaces, and that fan blades, if any, move freely.
7. Check that the Compressor is snug on all mounting pads.
8. Remove optional Water Strainer, when ordered, from shipping envelope, for installation in water supply line.
9. Use clean damp cloth or disposable paper wiper to wipe clean the interior surfaces of the ice storage Bin and the exterior surfaces of the cabinet.
10. See NAMEPLATE on the left section of the rear service panel of the cabinet and check that the location source voltage corresponds with the voltage specified on the nameplate.

CAUTION

Improper voltage supplied to the Ice-maker will void your parts replacement program.

11. Fill in all spaces of the Manufacturer's Registration Card including: Model Number and Serial Number taken from the aluminium plate located at the front left corner of the Base Assembly. Forward the completed, self-addressed, registration card to the SCOTSMAN factory.

III. LOCATION AND LEVELING

CAUTION

This Cuber is NOT designed for outdoor installations where air temperatures are below 50-degrees F., or above 100-degrees F. and the water temperature is below 40-degrees F. or above 100-degrees F. Extended periods of

operation at temperatures exceeding these limitations will constitute misuse, under the terms of the SCOTSMAN Manufacturer's limited warranty, resulting in LOSS of warranty coverage.

1. Position the Cuber in the selected permanent location.

NOTE

Prior consideration for location site shall include:

1. *Minimum room temperature 59-degrees F, and maximum room temperature 100-degrees F.*
 2. *Water inlet temperatures: Minimum 40-degrees F, and Maximum 100-degrees F.*
 3. *Well ventilated location for Air-Cooled model, advising user to frequently clean Condenser.*
 4. **SERVICE ACCESS:** *Adequate space for all service connections, through the left side or rear of the Cabinet. A six-inch minimum clearance at rear, side and front lowered panels, for routing cooling air drawn into and exhausted out of the compartment, to maintain proper condensing operation on Air-Cooled Models.*
2. Level the Cuber in both the left-to-right and front-to-rear directions. The optional leveling legs can be adjusted with an open-end wrench.

IV. ELECTRICAL CONNECTIONS

WARNING

This icemaker requires a **SOLID EARTH GROUND** that meets the national, state and local electrical code requirements. To prevent possible **SEVERE ELECTRICAL SHOCK INJURY** to individuals, or extensive damage to equipment, install an approved **SOLID EARTH GROUND** wire to the icemaker. SEE wiring diagram.

SEE NAMEPLATE for current requirements to determine wire size to be used for electrical hookup. The Cuber requires a solid earth ground wire. See wiring diagram.

Be certain the Cuber is connected to its own electrical circuit and individually fused. The maximum allowable voltage variation should not exceed ten percent of the nameplate rating, even under starting conditions. Low voltages can cause erratic operation and may be responsible for serious damage to the overload switch and motor windings.

All external wiring should conform to the National, State and local electrical code requirements. Usually an electrical permit and services of a licensed electrician will be required.

V. WATER SUPPLY AND DRAIN CONNECTIONS

A. AIR-COOLED MODELS: The recommended water supply line is a 1/4 inch O.D. copper tubing. Connect to cold water supply line with standard plumbing fittings, with a shutoff valve installed in an accessible place between the water supply and the Cuber.

The optional wire mesh strainer, when ordered, must be installed with the cleanout plug down. Locate the strainer in the water supply line, next to the Cuber with the arrow on the strainer, in the direction of the water flow. The strainer protects against large particles of rust, scale, etc., which may be loosened in the water supply pipe, at the time of installation.

CAUTION

To prevent damage to the freezer mechanism, **DO NOT** operate this unit when the water supply is OFF, or is below 20 PSI, the recommended water pressure. Position the master switch to the OFF position, until proper water supply is resumed.

The Icemaker in this Cuber will not operate properly when water supply temperatures are below 40-degrees F. or above 100-degrees F.

B. WATER-COOLED MODELS: On Water-cooled models a separate connection, to the Condenser is required. A 3/8-inch O.D. copper tubing is provided for a separate water inlet line to be connected and a separate drain line to be connected.

NOTE

The WARNING in the text above for the Air-cooled models equally applies for the Water-Cooled models. In both type installations, water supply must be installed to conform with local plumbing codes. In some cases, a plumbing permit and services of a licensed plumber will be required.

C. DRAIN CONNECTIONS: All drains are gravity type and must be 1/4-inch fall per foot on horizontal runs. The drains to be installed to conform with local code. The drain receptacle should be an open, trapped or vented construction.

Recommended Bin drain is 5/8-inch O.D. copper tubing, should be vented and run separately. Install a separate drain line to 3/8-inch O.D. drain tube from the Water-Cooled Condenser, on Water-Cooled models.

VI. FINAL CHECK LIST

1. Is the Cabinet level? (IMPORTANT)

2. Is the Cuber in a room where ambient temperatures are a minimum of 50-degrees F. all year around?
3. Is there at least a six-inch clearance behind and around the cabinet for all connections and for proper air circulation?
4. Have all electrical and piping connections been made?
5. Has the electrical power supply wiring been properly connected, and the voltage tested and checked against the nameplate rating? Has proper Chassis-to-earth ground been installed?
6. Is the water supply line shutoff valve installed and opened and has the inlet water supply pressure been checked to ensure a minimum of 20 PSIG?
7. Have the Compressor hold down bolts been checked to be sure the compressor is snug on the mounting pads?
8. Check all refrigerant lines and conduit lines to guard against vibration and possible failure.
9. Has the Cuber and the Bin been wiped clean with clean damp cloths?
10. Has the owner/user been given the User Manual and instructed on how to operate the icemaker and the importance of periodic maintenance?
11. Has the owner/user been given the name and telephone number of the Authorized SCOTSMAN Distributor or Service Agency serving him?
12. Has the Manufacturer's Registration Card been properly filled out? Check for correct Model and Serial Numbers from nameplate, then mail the completed card to the SCOTSMAN factory.

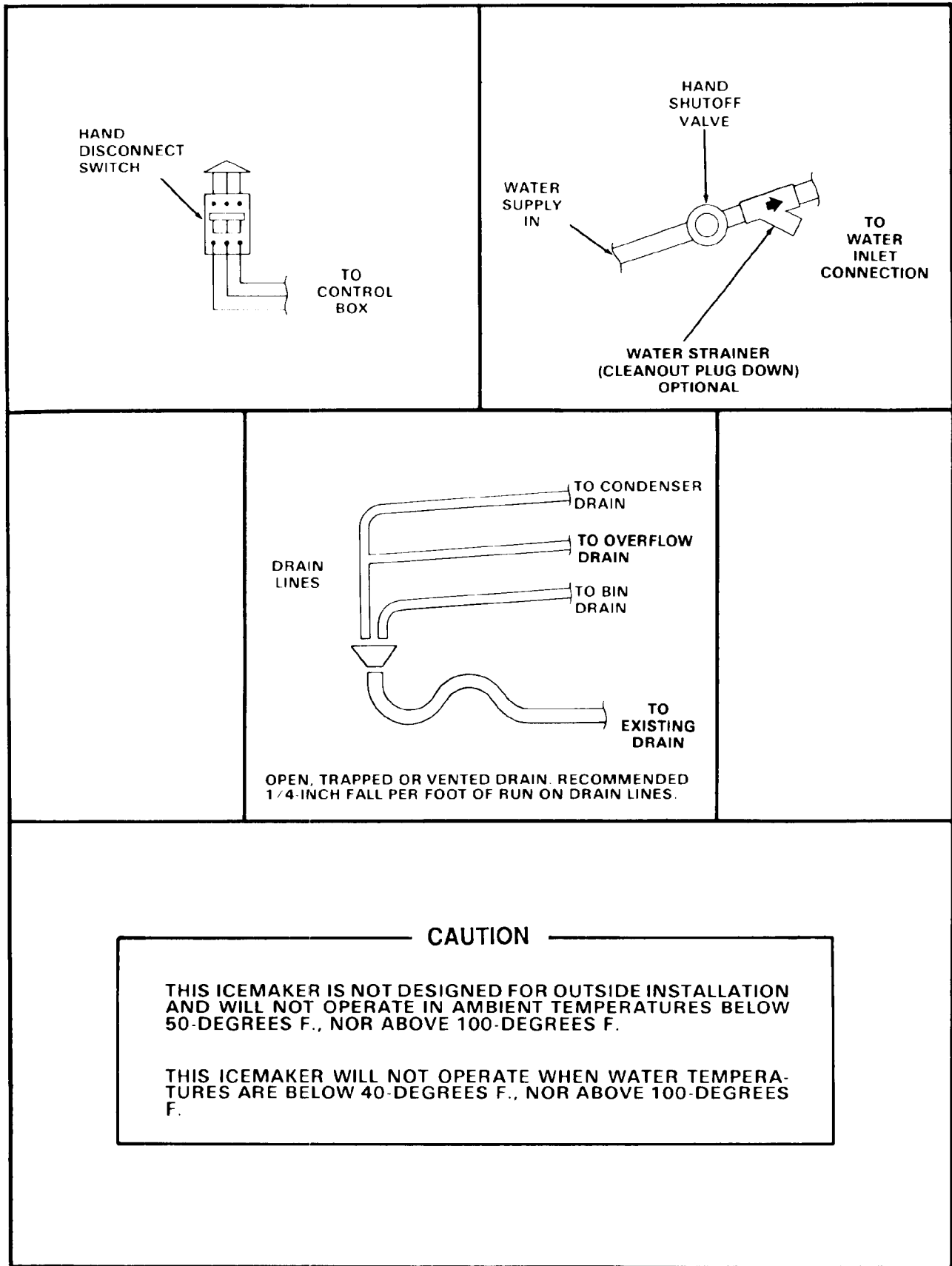

Figure 1-1. Installation Practice.

SECTION II OPERATING INSTRUCTIONS

I. START UP

1. Remove two screws, hinge bushings and the Ice Access Door.
2. Remove screws and the Upper Front Panel Assembly.
3. Remove the left Cover Moulding, three screws and the left Track Section, two screws and the Machine Compartment Baffle.
4. Check that the Master ON-OFF toggle switch and the Compressor ON-OFF toggle switch, on top of the Control Box are in the OFF position.
5. Rotate the shaft of the Timer & Switch Assembly, located in a hole in the Control Box Cover, **CLOCKWISE**, to start the Timer for filling the reservoir in the Freezing Chamber.

NOTE

*Slowly rotate the shaft **CLOCKWISE**, until the actuator arm on the microswitch drops off the outer cam into the cam slot. An audible click can be heard, but in a noisy area, look at the cam and switch to observe the event. See A, Figure 2-1.*

6. Move the Master ON-OFF toggle switch, to the ON position.

NOTE

*Observe that the Water Inlet Solenoid Valve **OPENS** and inlet water flows from the valve through tubing to the top of the Freezing Chamber, where the water flows around the inverted ice cube cups and drains through holes in the Platen Assembly and into the Reservoir. Excess water in the Reservoir is overflowed through the stand pipe. This cycle will take about three minutes, when the Timer will **CLOSE** the Water Inlet Solenoid Valve.*

7. Repeat step 5.

NOTE

*During **START UP**, advancing two harvest cycles, with the Compressor **OFF**, allows a check that: the Water Inlet Solenoid Valve operates; the incoming water flows; the Reservoir is filled in the preparation for the freezing cycle, and; checks the function of the overflow and drain.*

8. When the second cycle is completed, move the Compressor ON-OFF toggle switch to the ON position.
9. Check that the Left Cube Chute and the Right Cube Chute are properly positioned: with the rear edges resting on the rear shoulder of the Freezing Chamber; the Left Cube Chute fits snug around the left side part of the Freezing Chamber; the left edge of the Right Cube

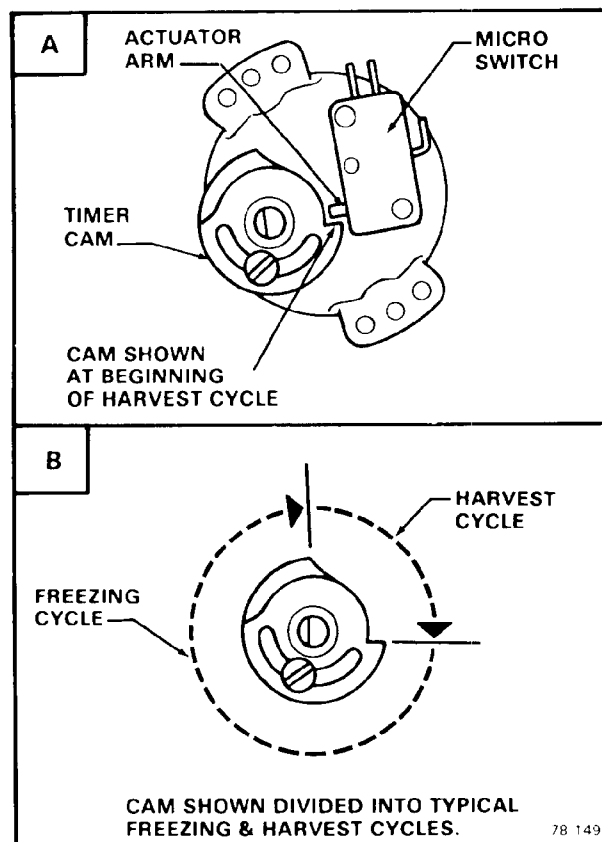

Figure 2-1. Timer Cam Positions.

Chute aligns with the right edge of the Left Cube Chute, and; both Cube Chutes are fastened at the bottom of the opening at the front of the Freezing Chamber.

10. Check that the bottom of the thin, clear plastic sheet of the Curtain Assembly hangs down, contacting the front edges of the two Cube Chutes.
11. Check operation of the Freezing cycle:
 - a. Compressor is in operation.
 - b. Agitator Motor is operating and the Spray Bar continuously rotates.
 - c. Water Pump is operating and water is being sprayed through the nozzles on the Spray Bar, into the inverted ice cups.
 - d. Icemaking process begins: feeling inside ice cube cups reveals cold temperatures and very shortly ice begins to form.

NOTE

Freezing time, in a 70-degree F. ambient atmosphere, will range between 14 and 18 minutes for small size ice cubes and 16 to 20 minutes for medium size ice cubes. Longer times for temperatures above 70-degrees F. and shorter, when below. Average times for complete cycles, range between 17 to 25 minutes.

CAUTION

DO NOT operate this icemaker when the water supply is shut OFF, or is BELOW the recommended 20 PSI water pressure. Move the Master ON-OFF toggle switch, the front toggle switch on the left end of the Control Box, to the OFF position, immediately.

12. Observe first ice cube harvests:
a. Check size of ice cubes:

NOTE

Normal cube size is with a one-quarter inch depression in the crown.

- b. **IF ICE CUBES ARE SHALLOW SIZE** (Indentation is too deep):
(1) Locate the Cube Size Control, in the right front of the Control Box; then, rotate the adjusting screw one-eighth of a turn **CLOCKWISE** toward **COLDER**.
(2) Observe size of ice cubes in next two ice cube harvests and repeat step (1) above, in one-eighth turn increments, until proper ice cube size is achieved.
- c. **IF ICE CUBES ARE OVERSIZE** (Indentation is too full):

(1) Locate the Cube Size Control, in the right front of the Control Box; then, rotate the adjusting screw one-eighth of a turn **COUNTERCLOCKWISE** toward **WARMER**.

(2) Observe size of ice cubes in next two ice cube harvests and repeat step (1) above, in one-eighth turn increments, until proper ice cube size is achieved.

d. Check texture of ice cubes: When partially cloudy throughout, suggests unit operating short of water near end of freezing cycle, or possibly an extreme water condition, wherein filtering or purifying equipment is recommended. Contact **SCOTSMAN - Queen Products Division, Service Department, Albert Lea, Minnesota**, for further details.

13. With the Icemaker in the Harvest Cycle, make contact using ice cubes on the Bin Thermostat Control Bulb, to test shutoff. The ice should cause the Icemaker to shut OFF, at the end of the Harvest Cycle.

NOTE

Within minutes after the ice is removed from the sensing bulb, the bulb will warm up and cause the icemaker to restart. This control is factory set and should not be reset until testing is performed. Normal setting is about 35-degrees F. CUT-OUT and 40-degrees F. CUT-IN.

14. Thoroughly explain to the owner/user the significant specifications of the Icemaker, the start up and operation, maintenance and cleaning procedures. Answer all questions about the Icemaker, by the owner; and inform the owner of the name and telephone number of the authorized **SCOTSMAN** Distributor or Service Agency serving him.

SECTION III PRINCIPLES OF OPERATION - How It Works

I. FREEZING CYCLE

Water from the sump in the Reservoir is pumped through the rotating Spray Bar Assembly, which consists of a spray bar and jets, rotating a full 360-degrees and through which water is sprayed into the inverted cube molds of the Freezer Assembly Evaporator. See Figure 3-1. At the beginning of the Freeze Cycle the electrical circuit is completed to the Compressor, Water Pump, and the coil of the Finish Relay. The Water Pump operates continuously during the Freeze Cycle through contacts of the Finish Relay. In Water-Cooled models water also flows through the Condenser and out the drain. While in the Condenser water removes heat from the refrigerant and allows the refrigerant to condense from a gas to a liquid.

Refrigerant is compressed in the Compressor and discharged into the Condenser as a high pressure, high temperature gas. The refrigerant is cooled and condensed by either air or water and condenses to a high pressure, high temperature liquid. This liquid refrigerant then passes through a small capillary tube where the temperature and pressure of the liquid refrigerant are lowered. The low pressure, low temperature liquid refrigerant, then enters the Evaporator. The refrigerant is

warmed by water being sprayed against the Evaporator and begins to boil off, to become a gas. The refrigerant next travels through the Accumulator where any remaining liquid refrigerant then returns to the Compressor as a low pressure, low temperature gas and the cycle starts again.

During the Freezing Cycle, both the Water Inlet Solenoid Valve and the Hot Gas Solenoid Valve are CLOSED.

When the ice cubes are about 3/4 formed, the Cube Size Control Bulb located on the suction line will sense the temperature at which it is preset to CLOSE. This will complete the electrical circuit to the Timer. The Timer then controls the remainder of the cycle.

The Timer will keep the Icemaker operating in the Freeze cycle for the next six minutes. This will give the cubes time to fully form. After six minutes, the Timer will switch the Icemaker into the Harvest Cycle, through the contacts of the Timer Assembly microswitch.

II. HARVEST CYCLE

When the Timer switches the Icemaker into the Harvest Cycle, hot gas being discharged from the Compressor is diverted through the Hot Gas Solenoid Valve into the Evaporator. During this

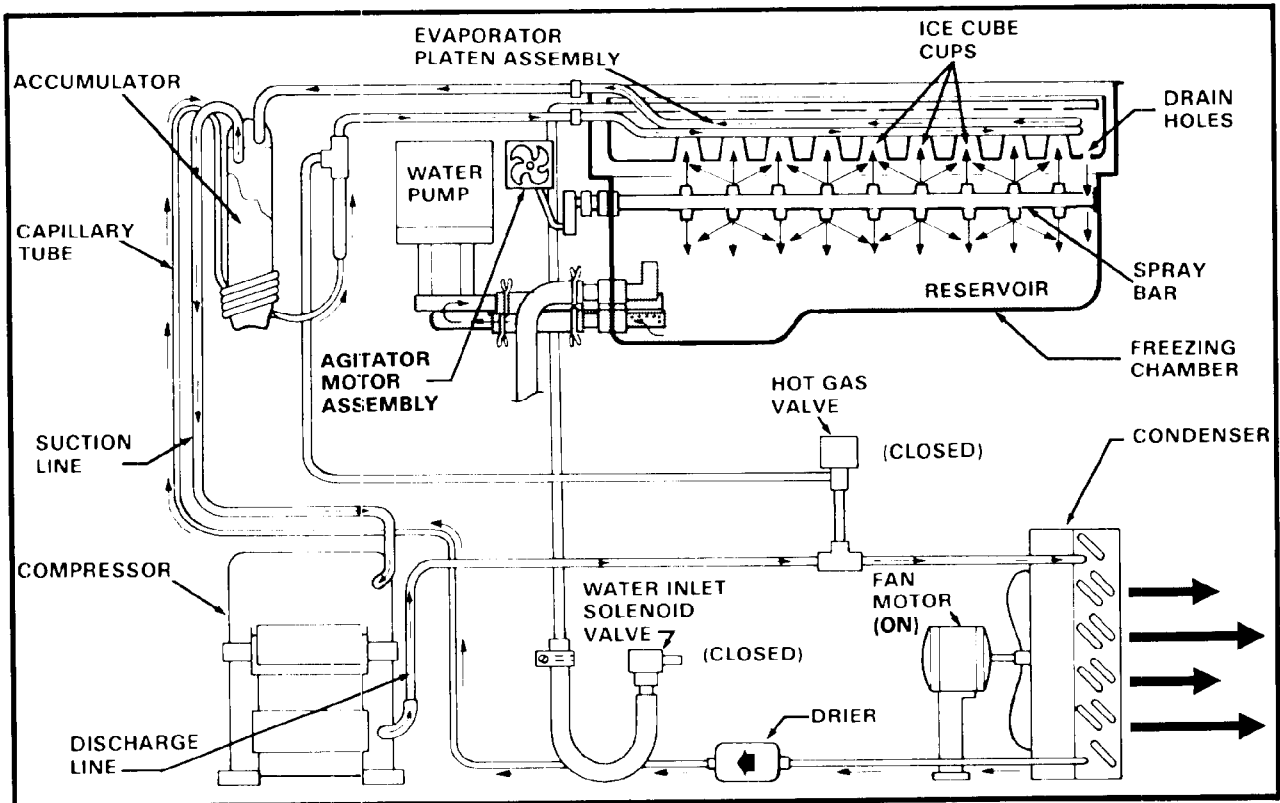
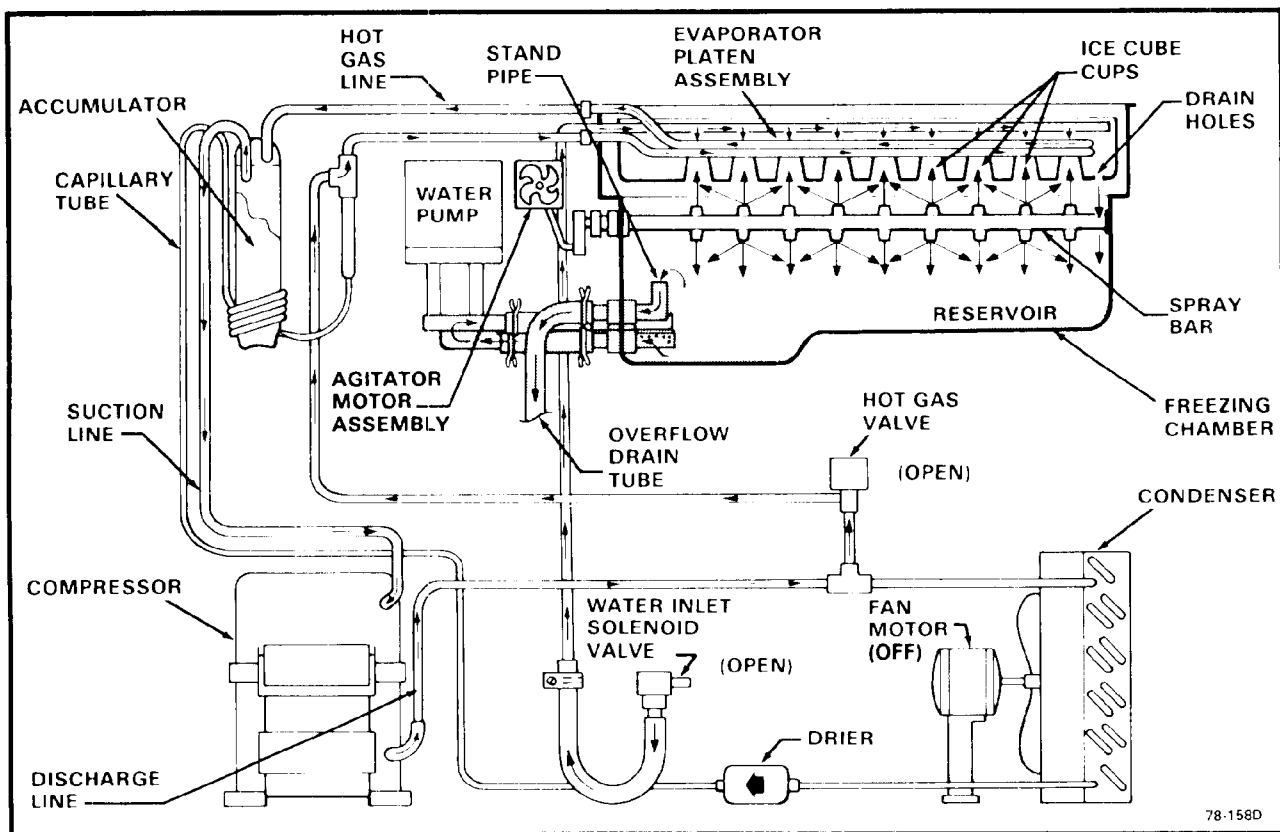

Figure 3-1. Freezing Cycle.



1. On Air-Cooled Models, the Water Pump Motor and Fan Motor may cycle intermittently during the Harvest Cycle.
2. On Water-Cooled Models, the Water Pump Motor is OFF during the Harvest Cycle.

Figure 3-2. Harvest Cycle.

cycle, the hot gas circulates from the Compressor to the Evaporator and back again, bypassing the Condenser and capillary tube. In the electrical circuit, the Compressor is operating and both the Water Inlet Solenoid Valve and the Hot Gas Solenoid Valve are energized.

See Figure 3-2. Opening the Water Inlet Solenoid Valve allows a fresh water supply to be discharged into the top of the Platen Assembly Evaporator. The finished ice cubes are released from the Evaporator by the warming effect of the hot gas flowing through the Evaporator tubes and the water flow around the ice molds. The released ice cubes drop onto the slanted Front Cube Chute and into the ice storage bin. At the end of the two minute Harvest Cycle, the Timer cam will push the actuator arm of the microswitch IN. If the Bin Thermostat is still CLOSED, a whole new cycle will begin. If the Bin Thermostat is OPEN, the Icemaker will shut OFF at this time.

III. COMPONENT DESCRIPTIONS

A. BIN THERMOSTAT CONTROL

The Bin Thermostat Control is located to the right of the Contactor in the upper rear section of the Control Box. The sensing capillary tube of the control is routed through the left wall of the Bin and clipped to the bottom of the front opening of the Freezing Chamber. The control functions to automatically SHUT OFF the Icemaker, when the ice storage bin is filled and ice contacts the capillary tube. It also signals the RESTART of the Icemaker when the capillary tube starts to warm up after ice has been removed from the bin. Factory settings are 35-degrees F. CUT-OUT and 40-degrees F. CUT-IN.

ALWAYS CHECK a replacement Bin thermostat Control BEFORE installing the control in the Cuber. Prepare a container of ice and water and insert a thermometer. As

temperature indications on the thermometer decrease to 35-degrees F., insert the capillary tube of the Bin Thermostat Control and determine temperature of CUT-OUT when an audible click is heard in the control. Slowly add hot water to container and check audible click in the control for CUT-IN while observing increase in temperature of water to 40-degrees F. Refer to procedure IV-I to adjust Bin Thermostat Control.

NOTE

The Bin Thermostat Control is wired through the holding relay and will not CUT-OUT the Icemaker until the end of the Harvest Cycle. Altitude adjustment should ONLY be performed on Ice-makers installed at 2,000-foot level locations and ABOVE, and adjust only in increments of one-fourth turn of screw at a time.

B. COMPRESSOR CONTACTOR

A single-pole contactor is used to supply current to the Compressor; and, is wired so any control in the pilot circuit, such as the Bin Thermostat and High Pressure Control, etc., will cause the contactor coil to be de-energized, when the control contact OPENS, thereby breaking the circuit to the Compressor through the contactor points.

C. CUBE SIZE CONTROL

The temperature sensing Cube Size Control affects the length of the Freezing Cycle prior to initiating the Finishing Timer. The Cube Size Control closes its contacts when the Evaporator reaches a preset temperature, starting the Finishing Timer. A variation in either ambient air or inlet water temperature will affect the efficiency of the refrigeration system. This will vary the length of time it takes the Evaporator to reach the temperature at which the Cube Size Control is preset to CLOSE; which, in turn, will affect the overall cycle time.

NOTE

Be sure to refer to procedure IV-II, Adjustment of the Cube Size Control, BEFORE attempting to adjust the control.

D. FINISHING TIMER - Timer & Switch Assembly

The function of the Finishing Timer begins when activated by the Cube Size Control. The Timer controls an eight minute dual function: six minutes are programmed to finish freezing the ice cubes and the final two minute portion is for the defrost operation and harvest of the ice cubes. All electrical circuitry is connected through the printed circuit board and the Finishing Timer and shunted by the single-pole, double-throw microswitch to either the Freezing Cycle or the Harvest Cycle. The microswitch is actuated by a Cam Assembly directly

connected to the Timer Motor. The Timer Cam can be adjusted to vary the defrost time, as required.

E. HIGH PRESSURE CONTROL - Water-Cooled Model

The High Pressure Control, a safety control, is factory set at 190 PSIG. The control functions as a precautionary device, to shut OFF electrical power to the Icemaker, should a loss of water occur to the water-cooled Condenser. In addition to being a manual reset control, there is an adjusting screw for raising or lowering the CUT-IN pressure.

F. HIGH PRESSURE FAN CONTROL - Air-Cooled Model

The High Pressure Fan Control functions only during the harvest cycle, to maintain head pressure. As an automatic reset device, the control is mechanically connected to the refrigerant system high side; and, electrically has both the Water Pump and the Condenser Fan Motor wired into control contacts. The control settings CLOSE at 150 PSIG and OPEN at 130 PSIG. During defrost, the control will usually cycle once, causing the Fan Motor and the Water Pump to briefly operate during this time.

G. HOT GAS SOLENOID VALVE

The Hot Gas Solenoid Valve functions only during the harvest cycle, to divert the hot discharge gas from the Compressor, by-passing the Condenser and capillary tube, for direct flow to the Evaporator Platen Assembly to release ice cubes from the inverted ice cube molds. The Hot Gas Solenoid Valve is comprised of two parts, the Body & Plunger and the Coil & Frame assemblies. Installed in the discharge line of the Compressor, the energized solenoid coil lifts the valve stem within the valve body to cause the hot discharge gas to be diverted when the Finishing Timer has advanced to the start of the harvest cycle.

H. FINISH RELAY

The multi-function, three-pole, double-throw, plug-in relay is installed directly into a receptacle on the printed circuit board in the Control box. The relay functions, in part, to by-pass the Bin Thermostat, to prevent the Icemaker from shutting OFF, when a filled-bin condition occurs, during the Freezing Cycle. The by-pass action serves to ensure full-sized ice cubes with each Harvest Cycle; and, to prevent short cycling on the Bin Thermostat. The relay also redirects the current flow through the High Pressure Fan Control to the Condenser Fan Motor and the Water Pump during the Harvest Cycle.

I. SPRAY BAR ASSEMBLY

The continuously rotating Spray Bar Assembly is designed to channel recirculating water to groups of attached water jets for uniformly spraying the water into the inverted ice cube cup molds.

NOTE

Refer to procedure V-III, CLEANING - Icemaker; and, for problems requiring removal of parts refer to procedure IV-XII-A for details for removing Spray Bar Assembly and assorted parts.

J. WATER INLET SOLENOID VALVE

The Water Inlet Solenoid Valve functions only during the Harvest Cycle, when it is energized to permit continuous inlet water, to flow through the Defrost Tube onto the top of the plastic Platen Assembly, assisting in the harvest of ice cubes. The water drains through holes in the Platen Assembly into the Reservoir in the lower section of the Freezing Chamber; and there, the water is recirculated through the Water Pump for return to the Spray Bar Assembly.

K. WATER REGULATOR VALVE - Water-Cooled Models

The Water Regulator Valve functions to maintain a constant head pressure, by reg-

ulating the amount of inlet water flow through the Condenser, on water-cooled models. The valve operates through the refrigerant system high side pressure. Rotating the adjusting screw, located on top of the valve, can INCREASE or DECREASE the operating head pressure.

NOTE

When installing a replacement Water Regulator Valve, be sure the replacement valve is installed with the arrow positioned in the direction of the water flow.

REFRIGERANT CHARGE

MODEL	AC25 Refrig. Chg.
Air-Cooled	16.5 oz. R-12 (Approx.)
Water-Cooled	16.5 oz. R-12 (Approx.)

NOTE

Always CHECK NAMEPLATE on individual Icemaker for specific refrigerant charge, BEFORE charging the refrigeration system. The above listed refrigerant charges are approximate charges for the AC25 Cuber, however, it is important to CHECK NAMEPLATE for each Icemaker.

SECTION IV.

ADJUSTMENT AND REMOVAL AND REPLACEMENT PROCEDURES

The procedures provided in this Section are arranged in alphabetical order, to make specific Adjustment and Removal and Replacement information easy to locate.

Read the instructions thoroughly before performing any Adjustment or Removal and Replacement Procedures.

I. ADJUSTMENT OF THE BIN THERMOSTAT CONTROL

The control for the Bin Thermostat is the Temperature Control, located in the rear section of the Control Box.

CAUTION

The adjusting screws on the Temperature Control device have very sensitive response to adjustment. **DO NOT** attempt to adjust the screw until after thoroughly reading and understanding the following instructions and illustrations. Over-adjusting or erratic guessing, can foul the instrument and cause ultimate delay and part replacement, **WHICH COULD HAVE BEEN PREVENTED.**

Adjustment for **ALTITUDE CORRECTION** should only be performed for installations at 2000-feet and **ABOVE**. Carefully adjust only in one-fourth turn of screw at a time. **NO ALTITUDE CORRECTION** adjustments should be performed **BELOW** the 2000-foot level.

See Figure 4-1 for location and direction of rotation, clockwise (CW) or counterclockwise (CCW), of the adjusting screw on the Temperature Control, in the particular Control Box the adjustment is to be performed.

II. ADJUSTMENT OF THE CUBE SIZE CONTROL

CAUTION

BEFORE performing actual adjustment to the Cube Size Control, check other possible causes for cube size problems, refer to Section VI, **SERVICE DIAGNOSIS** for problem review and analysis.

DO NOT perform adjustment when a new Cube Size Control is installed, until the control bulb has been properly installed, in the tube well, on the refrigerant tube of the Platen Assembly and the icemaker has progressed through several complete freezing and harvest cycles, to observe size and quality of ice cubes and whether or not a cube size problem exists.

As a reverse acting temperature control, adjustment on the Cube Size Control is performed to either cause larger sized ice cubes or smaller sized ice cubes to be produced.

A. IF ICE CUBES ARE SHALLOW SIZE (Indentation is too deep):

1. Locate the Cube Size Control in the right front section of the Control Box.
2. Rotate the adjusting screw one-eighth of a turn **CLOCKWISE** toward **COLDER**.
3. Observe size of ice cubes in next two ice cube harvests and repeat step 2 above, in one-eighth turn increments, until proper ice cube size is achieved.

B. IF ICE CUBES ARE OVERSIZE (Indentation is too full):

1. Locate the Cube Size Control in the right front section of the Control Box.
2. Rotate the adjusting screw one-eighth of a turn **COUNTERCLOCKWISE** toward **WARMER**.
3. Observe size of ice cubes in next two ice cube harvests and repeat step 2 above, in one-eighth turn increments, until proper ice cube size is achieved.

III. ADJUSTMENT OF THE TIMER & SWITCH ASSEMBLY

The Timer & Switch Assembly is factory set, so that one complete revolution of the cam on the Timer represents eight minutes. Six minutes comprise the freezing cycle event during cam rotation, and the final two minutes program the defrost and harvest cycle. Rotating the shaft of the Timer Cam, **CLOCKWISE** will allow positioning the actuator arm of the microswitch on the cam at the selected start position for either the freezing cycle or harvest cycle, as required, during the **START UP** procedures and in the **CLEANING** instructions. Rotating the shaft **COUNTERCLOCKWISE** will unscrew the shaft from the threaded stud on the Timer Cam.

To Adjust the Timer Switch Assembly:

- #### A. HARVEST CYCLE:
- Slowly rotate the shaft of the Timer & Switch Assembly, located in the hole in the front of the Control Box Cover **CLOCKWISE**, until the actuator arm on the microswitch drops off of the outer cam into the cam slot. An audible click can be heard, but in a noisy area, look at the cam and switch to observe the event. See Figure 4-2.

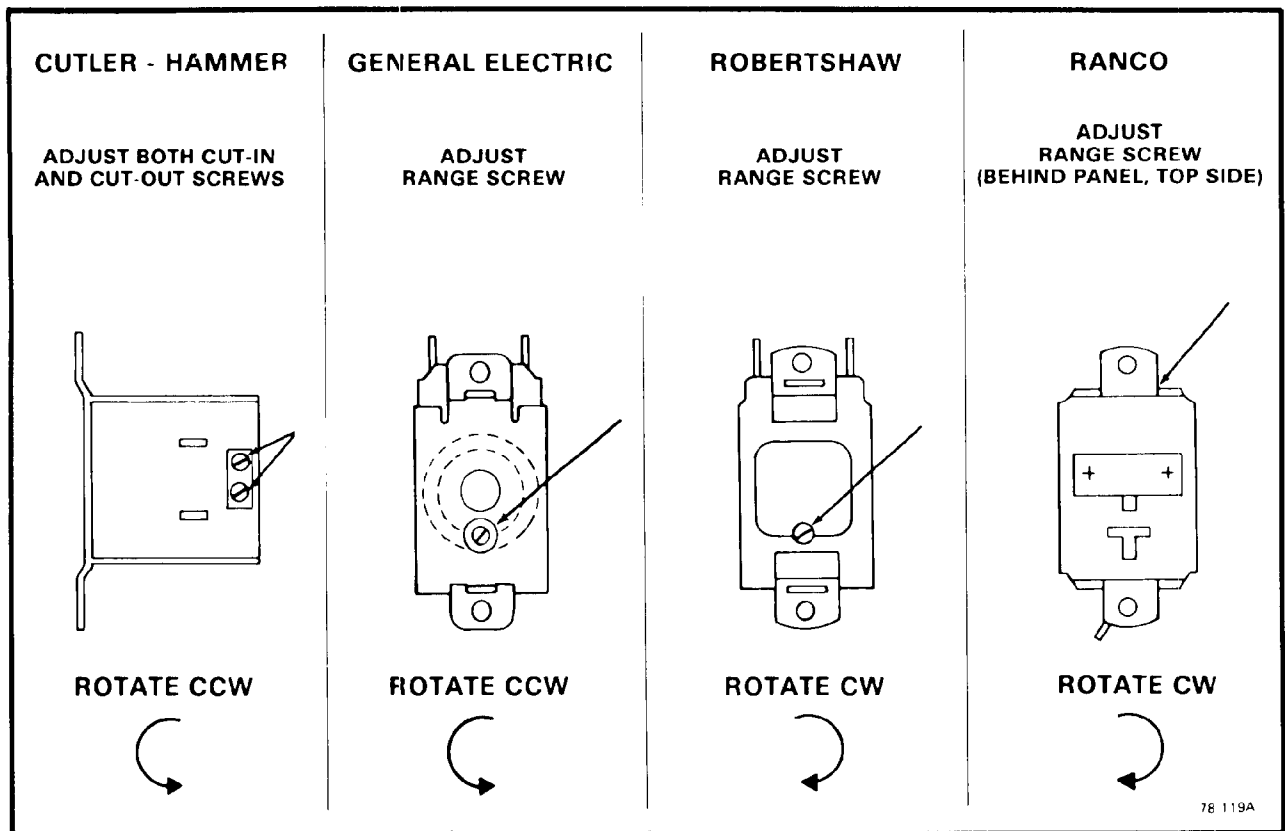

Figure 4-1. Adjustment of the Temperature Control.

B. FREEZING CYCLE: Slowly rotate the shaft of the Timer & Switch Assembly, located in the hole in the front of the Control Box Cover, CLOCKWISE, until the actuator arm on the microswitch rides up out of the cam slot to the start of the surface of the outer cam.

IV. ADJUSTMENT OF THE WATER REGULATOR ASSEMBLY - WATER-COOLED MODELS

The correct head pressure on Water-Cooled models is 135 PSIG. Adjustments can be performed on the Water Regulator Assembly to increase or decrease head pressure.

To Adjust Water Regulator Assembly:

A. To INCREASE the Head Pressure: Rotate the adjusting Screw, on the Water Regulator Assembly COUNTERCLOCKWISE.

B. To DECREASE the Head Pressure: Rotate the adjusting Screw, on the Water Regulator Assembly CLOCKWISE.

WARNING

Be sure the electrical power supply and the water supply are OFF, BEFORE starting any of the following REMOVAL AND REPLACEMENT procedures as a precaution to prevent possible personal injury or damage to equipment.

V. REMOVAL AND REPLACEMENT OF THE AGITATOR MOTOR ASSEMBLY

A. To Remove the Agitator Motor Assembly:

1. Remove screws and the Top Panel Assembly.
2. Remove two screws, hinge bushings and the Ice Access Door.
3. Remove screws and the Upper Front Panel Assembly.
4. Remove the left Cover Moulding.
5. Remove all screws that directly attach to the Left Side Panel, at the left end ONLY, of the Back Panel, Left Track Section, Machine Compartment Baffle, and the Lower Left Front Panel; then, carefully remove the Left Side Panel.
6. Remove screws and the Control Box Cover; then, disconnect the electrical leads of the Agitator Motor, from the terminals on the printed circuit board, in the Control Box.
7. Remove four screws attaching the Agitator Motor Assembly to the Bin wall and remove the Agitator Motor Assembly.

B. To replace the Agitator Motor Assembly, reverse the removal procedures.

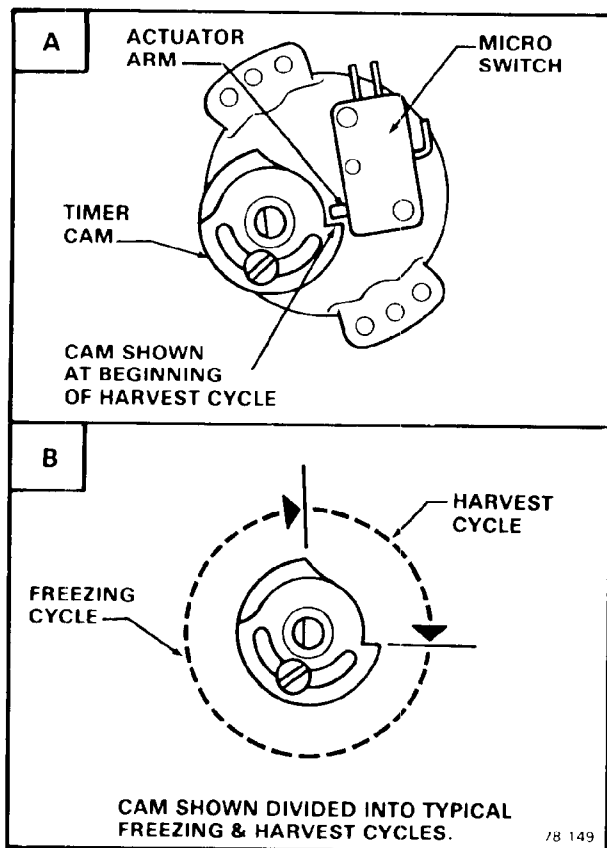

Figure 4-2. Adjustment of the Timer & Switch Assembly

VI. REMOVAL AND REPLACEMENT OF THE COMPRESSOR ASSEMBLY

NOTE

Always install a replacement Drier, anytime the sealed refrigeration system is opened. Do not replace the Drier until all other repair or replacement has been completed.

A. To remove the Compressor Assembly:

1. Perform steps 1 through 5, in procedure IV-V-A, to gain access to the Compressor Assembly.
2. Remove screws and the Cover from the Compressor Junction Box.
3. Disconnect the electrical leads in the Compressor Junction Box, that connect to the Control Box.
4. Bleed off or blow the refrigerant charge through the Schrader valve.
5. Unsolder and disconnect both the refrigerant suction line and the discharge line from the Compressor.
6. Remove four bolts, washers, mounting sleeves, and grommets which secure the Compressor to the Chassis mounting base.

7. Remove the Compressor Assembly from the base.

NOTE

Thoroughly evacuate the system to remove moisture and non-condensables.

- B. To replace the Compressor Assembly, reverse the removal procedure.

VII. REMOVAL AND REPLACEMENT OF THE CONDENSER ASSEMBLY - AIR-COOLED MODELS

NOTE

Always install a replacement Drier, anytime the sealed refrigeration system is opened. Do not replace the Drier until all other repair or replacement has been completed.

A. To remove the Condenser:

1. Perform steps 1 through 5, of procedure IV-V-A, to gain access to the Condenser Assembly.
2. Disconnect the electrical leads of the Fan Motor.
3. Remove four screws and lift the Fan Motor Assembly and shroud from the Condenser Assembly.
4. Bleed off or blow the refrigerant charge through the Schrader valve.
5. Unsolder and disconnect the refrigerant lines from the Condenser.
6. Remove four hex screws, lift and remove the Condenser Assembly from the Condenser Mounting Brackets.

- B. To replace the Condenser, reverse the removal procedure.

VIII. REMOVAL AND REPLACEMENT OF THE CONDENSER ASSEMBLY - WATER-COOLED MODELS.

NOTE

Always install a replacement Drier, anytime the sealed refrigeration system is opened. Do not replace the Drier until all other repair or replacement has been completed.

A. To remove the Condenser:

1. Perform steps 1 through 5, of procedure IV-V-A, to gain access to the Condenser Assembly.
2. Bleed off or blow the refrigerant charge through the Schrader Valve.
3. Unsolder and disconnect the refrigerant lines from the Condenser.
4. Remove two hex screws, lift and remove the Condenser Assembly from the Condenser Bracket.

- B. To replace the Condenser, reverse the removal procedure.

IX. REMOVAL AND REPLACEMENT OF THE CUBE CHUTES AND CURTAIN ASSEMBLY

A. To remove the Cube Chutes and the Curtain Assembly:

1. Remove two screws, hinge bushings and the Ice Access Door.
2. Remove screws and the Upper Front Panel Assembly.
3. Remove screws at each end of the Cube Deflector and remove the Cube Deflector from the front of the Freezing Chamber.
4. Remove the two middle screws of the Curtain Assembly, and remove the Curtain Assembly from the front opening of the Freezing Chamber.
5. Lift the clips, on the front edge of the Left and Right Cube Chutes, up from the lower part of the front opening of the Freezing Chamber and remove the two Cube Chutes from the Freezing Chamber.

NOTE

Carefully observe the positions of the two Cube Chutes, for correct repositioning during the replacement procedures. The full straight sides of both Cube Chutes should fit together, when the ends of the Cube Chutes with the clips, are at the bottom.

B. To replace the Cube Chutes and the Curtain Assembly, reverse the removal procedure.

X. REMOVAL AND REPLACEMENT OF THE DRIER

NOTE

Always install a replacement drier, anytime the sealed refrigeration system is opened. Do not replace the Drier until all other repair or replacement has been completed.

A. To remove the Drier:

1. Lift the Ice Access Door and tape the Door in the fully open position.
2. Remove the left Cover Moulding, three screws and the left Track Section.
3. Remove screws and the Machine Compartment Baffle.
4. Remove screws and the left Lower Front Panel.
5. Remove screw and Drier Brace attaching the Drier to the Chassis base.
6. Bleed off or blow the refrigerant through the Schrader valve.
7. Unsolder refrigeration lines at each end of the Drier, remove the Drier and separate the Drier from the Drier Brace.

B. To replace the Drier:

CAUTION

1. If the factory seal is broken on the replacement Drier, exposing it to the atmosphere more than a few minutes, the Drier will absorb moisture from the atmosphere and lose substantial ability for moisture removal.
2. Be sure the replacement Drier is installed with the arrow positioned in the direction of the refrigerant flow.

1. Remove the factory seals from the replacement Drier and install the Drier in the refrigerant lines with the arrow positioned in the direction of the refrigerant flow.
2. Install the Drier Brace on the Drier.
3. Solder the Drier into the lines, two places.
4. Purge the system and check for leaks.
5. Thoroughly evacuate the system to remove moisture and non-condensables.
6. Charge the system with refrigerant, by weight. SEE NAMEPLATE.
7. Reverse the removal procedures to replace other parts and panels.

XI. REMOVAL AND REPLACEMENT OF THE FAN MOTOR ASSEMBLY

NOTE

Before beginning this procedure, observe the Fan Blade position on the shaft of the Fan Motor and mark the Fan Blade so it will be correctly positioned during reassembly. Direction of air flow should be toward the Fan Motor.

A. To remove the Fan Motor Assembly:

1. Perform steps 1 through 5, of procedure IV-V-A, to gain access to the Fan Motor Assembly.
2. Disconnect the electrical leads of the Fan Motor.
3. Remove four screws and lift the Fan Motor Assembly and Shroud from the Condenser Assembly.
4. Remove four screws and separate the Shroud from the Fan Motor Assembly.
5. Remove the nut from the end of the Fan Motor Shaft and remove the Fan Blade.
6. Remove four screws and separate the two wire Fan Motor Mounting Assemblies from the Fan Motor.

B. To replace the Fan Motor Assembly, reverse the removal procedures.

XII. REMOVAL AND REPLACEMENT OF THE FREEZING CHAMBER, PLATEN ASSEMBLY AND SPRAY BAR ASSEMBLY

NOTE

Always install a replacement Drier, anytime the sealed refrigeration system is opened. Do not replace the Drier until all other repair or replacement has been completed.

A. To remove the Freezing Chamber, Platen, Spray Bar: (See Figure 4-3)

1. Remove two screws, hinge bushings and the Ice Access Door.
2. Remove screws, the Top Panel Assembly and the Upper Front Panel Assembly.
3. Remove screws and the Top Brace and spacer.
4. Remove screws at each end of the Cube Deflector and remove the Cube Deflector from the front of the Freezing Chamber.
5. Remove the two middle screws of the Curtain Assembly and remove the Curtain Assembly from the front opening of the Freezing Chamber.
6. Lift the clips, on the front edge of the Left

and Right Cube Chutes, up from the lower part of the front opening of the Freezing Chamber and remove the two Cube Chutes from the Freezing Chamber.

NOTE

Carefully observe the positions of the two Cube Chutes, for correct repositioning during the replacement procedures. The full straight sides of both Cube Chutes should fit together, when the ends of the Cube Chutes with the clips, are at the bottom.

7. Remove four screws attaching the Agitator Motor Assembly to the Bin wall and remove the Agitator Motor Assembly, to disengage from the Spray Bar Drive Housing Assembly.
8. Carefully withdraw the capillary tube, of the Bin Thermo Control, from the two clips on the bottom front opening of the Freezing Chamber, temporarily pulling it through the rubber grommet in the left wall of the Bin, out of the way.
9. Lift the Defrost Tube out of the top front of the Freezing Chamber.
10. Carefully remove the coiled capillary bulb from the Bulb Holder Clip (s) attached to

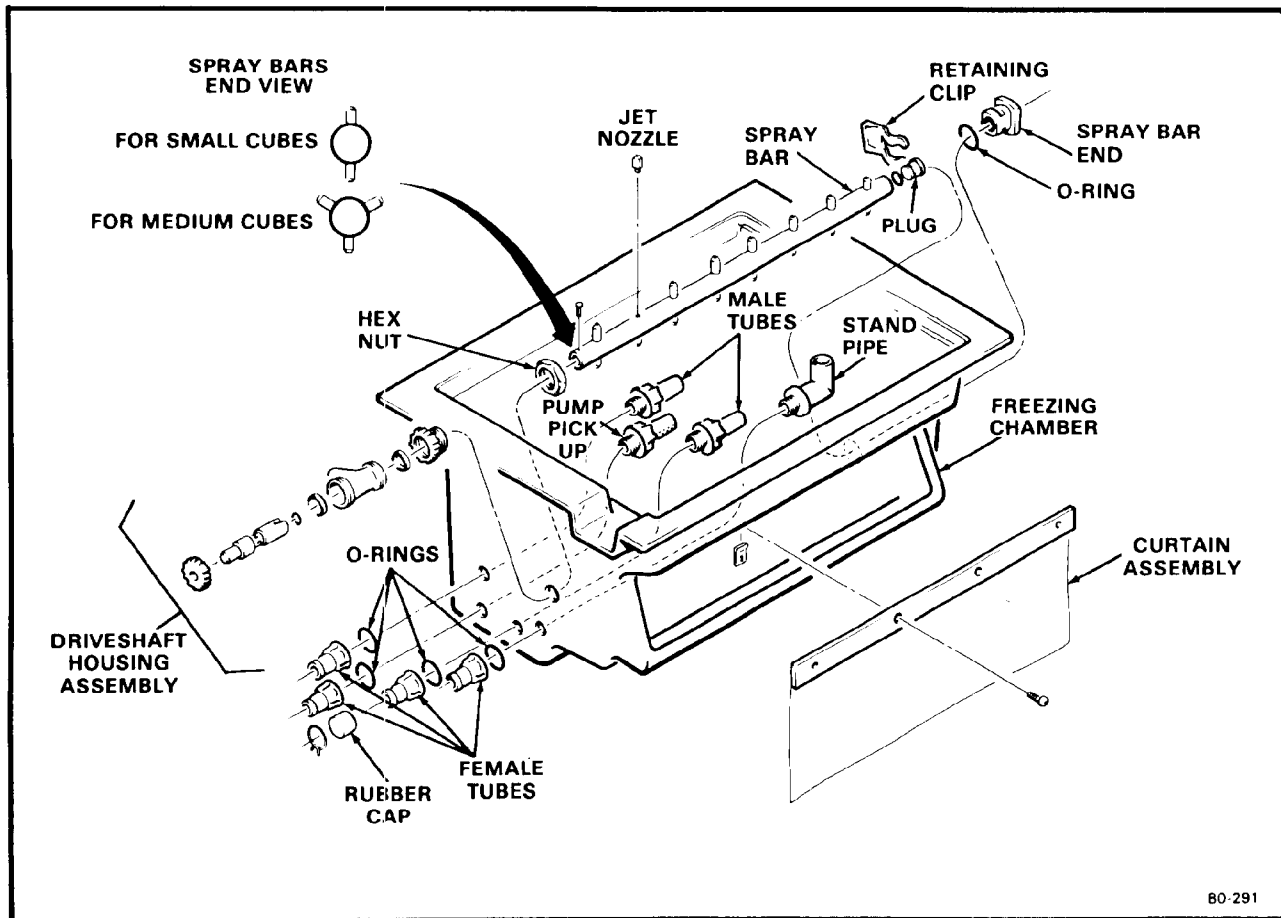

Figure 4-3. Freezing Chamber Disassembly.

the inlet line of the Platen Assembly; and position the capillary tube out of the work area.

11. Bleed off or blow the refrigerant charge through the Schrader valve.
12. Unsolder both the inlet and outlet refrigerant lines at the Platen Assembly and lift the Platen Assembly out of the top of the Freezing Chamber.

NOTE

For the next step, there is the option of removing hose clamps on the Tygon Tubes, inside the Bin, connected to the Freezing Chamber; or, outside the Bin wall, connected to the Water Pump Assembly. The removal of the Water Pump may be necessary, which also may require removal of the Back Panel, all depending upon individual decision for ease of access to those parts.

13. Remove hose clamps connecting Tygon Tubes to the left side of the Freezing Chamber.
14. Remove screws attaching the top flanges of the Freezing Chamber to the top of the rear and side walls of the Bin; then, lift the right side of the Freezing Chamber, working loose the Tygon Tubes from the left side, to free and remove the Freezing Chamber from the Bin, allowing any water to drain into the Bin.
15. Remove the Retaining Clip, Spray Bar End, O-Ring, and the Spray Bar from the Freezing Chamber; then, remove the Spray Bar Plug from the end of the Spray Bar. See Figure 4-3.
16. Unscrew four Female Tubes and O-Rings from the left outside of the Freezing Chamber, connected to two Male Tubes, one Pump Pick-up Tube and one Stand Pipe, installed from inside the Freezing Chamber.
17. Unscrew the Hex Nut, inside the Freezing Chamber, and remove the Driveshaft Housing Assembly.
18. Disassemble the Driveshaft Housing for inspection and possible replacement of any cut, torn, or badly worn O-Rings or Water Seals.
19. Inspect the Spray Bar and all nozzles for dirty or clogged condition, requiring cleaning or removal and replacement.

B. To replace, reverse the removal procedures.

XIII. REMOVAL AND REPLACEMENT OF THE WATER PUMP ASSEMBLY

A. To remove the Water Pump Assembly:

1. Remove two screws, hinge bushings and the Ice Access Door.
2. Remove screws, the Top Panel Assembly and the Upper Front Panel Assembly.

NOTE

For Water Pump removal, there is the option of removing hose clamps on the Tygon Tubes, inside the Bin wall, connected to the Water Pump Assembly. This also requires removal of the Back Panel, for easier access to parts; and, depending upon individual decision, removal of the Agitator Motor would give easier access to hose clamps at the Water Pump.

3. Remove hose clamps on Tygon Tubes of the Water Pump, inside or outside Bin Wall.
4. Disconnect electrical lead wires and ground wire from the Water Pump.
5. Remove two screws and the Water Pump Assembly from the Pump Bracket.

B. To replace the Water Pump Assembly, reverse the removal procedure.

XIV. REMOVAL AND REPLACEMENT OF THE WATER REGULATOR ASSEMBLY - WATER-COOLED MODELS

NOTE

Always install a replacement Drier, anytime the sealed refrigeration system is opened. Do not replace the Drier until all other repair or replacement has been completed.

A. To remove the Water Regulator Assembly:

1. Remove screws and the Top Panel Assembly.
2. Bleed off or blow the refrigerant charge through the Schrader valve.
3. Unsolder the capillary tube of the Water Regulator, at the Tee, leading to the process header.
4. Disconnect the water inlet line, two places, at the front and rear of the Water Regulator valve.
5. Remove two screws which attach the Water Regulator and mounting Bracket to the Condenser Bracket and remove the Water Regulator and Mounting Bracket.

NOTE

Thoroughly evacuate the system to remove moisture and non-condensables.

B. To replace the Water Regulator Assembly, reverse the removal procedures.

SECTION V MAINTENANCE & CLEANING INSTRUCTIONS

I. GENERAL

The periods and procedures for maintenance and cleaning are given as guides and are not to be construed as absolute or invariable. Cleaning especially will vary, depending upon local water conditions and the ice volume produced; and, each Icemaker must be maintained individually, in accordance with its own particular location requirements.

II. ICEMAKER

THE FOLLOWING MAINTENANCE SHOULD BE SCHEDULED AT LEAST TWO TIMES PER YEAR ON THIS ICEMAKER. CALL YOUR AUTHORIZED SCOTSMAN SERVICE AGENCY.

1. Check and clean water line Strainer.
2. Check that the Cuber is level, in side-to-side and front-to-rear directions.
3. Clean the water system Evaporator, Freezing Chamber Reservoir and Spray Bar, using a solution of SCOTSMAN Ice Machine Cleaner. Refer to procedure V-III, CLEANING - Icemaker.

NOTE

Cleaning requirements vary according to local water conditions and individual user operation. Continuous check of the clarity of ice cubes and visual inspection of the water spray bar and jets, before and after cleaning will indicate frequency and procedure to be followed in local areas.

4. Check that the lower edge of the Curtain Assembly hangs down, contacting the front edges of the two Cube Chutes.
5. Check and tighten all bolts.
6. Check and tighten all electrical connections.
7. Check Hot Gas Solenoid Valve for correct operation and high pressure controls for cut-in and cut-out pressures.
8. With Icemaker and Fan Motor OFF on Air-Cooled Models, clean Condenser, using vacuum cleaner, whisk broom or brush. Instruct customer to clean frequently. DO NOT USE A WIRE BRUSH.
9. Check that Fan Blades move freely, are not touching any surfaces and are not bent or out of balance.
10. Check for refrigerant leaks and tighten line connections.
11. Check for water leaks and tighten drain line connections. Pour water down bin drain line to be sure that drain line is open and clear.

12. Check size, condition and texture of ice cubes. Perform adjustments as required. Refer to procedure II-I-12.
13. Check Bin Thermostat Control Bulb to test shutoff. With the Icemaker in the harvest cycle, hold ice cubes on the Bulb, which should cause the Icemaker to shut OFF at the end of the harvest cycle.

NOTE

Within minutes after the ice is removed from the sensing bulb, the bulb will warm up and cause the Icemaker to restart. This control is factory set and should not be reset until testing is performed. Normal setting is about 35-degrees F. CUT-OUT and 40-degrees F. CUT-IN.

III. CLEANING - Icemaker

1. Remove screws, hinge bushings and the Ice Access Door, Upper Front Door, Left Cover Moulding, Left Track Section, Cube Deflector, and the Machine Compartment Baffle.
2. Move both the Master ON-OFF toggle switch and the Compressor ON-OFF toggle switch to the OFF position, on the Control Box.
3. Rotate the shaft of the Timer & Switch Assembly, located in the hole in the front of the Control Box Cover, CLOCKWISE, until the actuator arm on the microswitch rides up out of the cam slot, to the outer surface of the cam, then stop. This is the start position for the freezing cycle. See Figure 5-1.

WARNING

SCOTSMAN Ice Machine Cleaner contains Phosphoric and Hydroxyacetic acids. These compounds are corrosive and may cause burns if swallowed, DO NOT induce vomiting. Give large amounts of water or milk. Call physician immediately. In case of external contact, flush with water. KEEP OUT OF THE REACH OF CHILDREN.

4. Position container under left side of Freezing Chamber, remove Hose Clamp and Rubber Cap from center Female tube and drain water from Reservoir. Replace Rubber Cap and Hose Clamp.
5. Prepare cleaning solution: Mix eight ounces of SCOTSMAN Ice Machine Cleaner with six pints of fresh potable water.
6. Carefully pour the cleaning solution into the Freezing Chamber through the front opening.

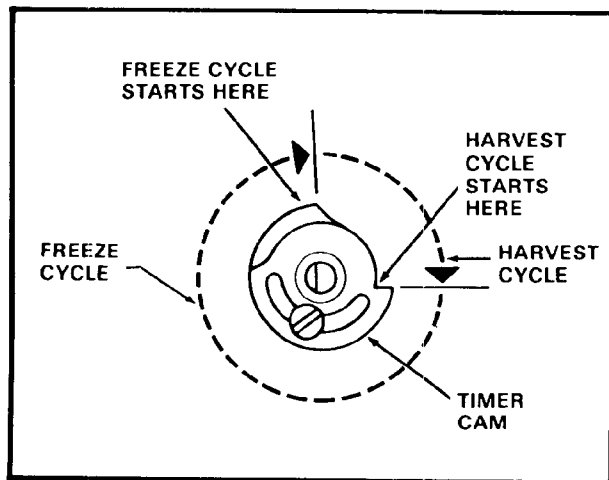

Figure 5-1. START Positions for the Freeze/Harvest Cycles.

7. Immediately move the Master ON-OFF toggle switch to the ON position.
8. Allow the system to operate for about twenty minutes.

NOTE

No ice cubes will be made, because the Compressor switch is OFF.

9. At end of twenty minutes, rotate the shaft of Timer & Switch Assembly, CLOCKWISE, to start a second harvest cycle. Repeat procedure to effect four complete harvest cycles. See Figure 5-1.

NOTE

During each harvest cycle, fresh inlet water is introduced into the water system and acts to rinse all water-related parts and to wash away most mineral concentration through the Reservoir overflow drain.

10. Move the Compressor ON-OFF toggle switch to the ON position.
11. Check each ice cube harvest, until the ice cubes are clear and the acid taste eliminated.

CAUTION

DO NOT use ice cubes produced from the cleaning solution. Be sure none remains in the Bin.

12. Add hot water to the Bin to melt the ice cubes; or, remove and discard all ice cubes.
13. Move both the Master ON-OFF toggle switch and the Compressor ON-OFF toggle switch to the ON position, to restart the Ice maker.
14. Replace Cube Deflector, Baffle, Track Section, Moulding, Doors in reverse order and secure with hinge bushings and screws removed earlier.

IV. SANITIZING

Sanitizing is an important phase of the ice-making operation. The following sanitizing procedure should be performed after every repair or replacement of parts in the Cuber, in or through which ice is formed, released and stored and water is drained. Additional requirements for performing the sanitizing procedure should be followed in accordance with the requirements of the Local Health Authorities.

NOTE

Contact your Local Health Authorities and obtain their approval of the sanitizer you intend to use when sanitizing the Cuber.

Prior to performing the sanitizing procedure, it is assumed the Front Panel has been removed and the cleaning procedure performed.

WARNING

Read WARNING thoroughly BEFORE preparing sanitizing solution, in next step.

1. STERILEX 3-O SANITIZING TABLETS

DANGER: KEEP OUT OF REACH OF CHILDREN. Tablets may be harmful or fatal if swallowed. May cause skin irritation or eye damage. Avoid prolonged skin contact. Do not get in eyes. In case of contact, flush with plenty of water. If irritation persists get medical attention. Avoid contamination of food.

FIRST AID: If tablets are swallowed, drink promptly a large quantity of milk, egg whites or gelatin solution. Avoid alcohol.

NOTE TO PHYSICIAN: Probable mucosal damage may contraindicate the use gastric lavage. Measures against circulatory shock, respiratory depression and convulsion may be needed. Rinse empty carton thoroughly with water and discard. Always follow your health department regulations.

2. MIKRO-QUAT

DANGER: Causes high damage and skin irritation. Do not get in eyes, on skin, or on clothing. Protect eyes when handling concentrated product. Harmful if swallowed. Avoid contamination of food.

FIRST AID: In case of contact, immediately flush eyes or skin with plenty of water for at least 15 minutes. For eyes, call a physician. Remove and wash contaminated clothing before reuse. If swallowed, drink promptly a large quantity of milk, egg whites or gelatin solution or if these are not available, drink a large quantity of water. Call a physician immediately.

1. Prepare a sanitizing solution using a quaternary ammonium sanitizing compound.

NOTE

1. Carefully follow directions and observe all precautions on the sanitizing compound container.
2. One *Sterilex 3-Q sanitizing tablet per three quarts of water yields 220 ppm active quaternary; or, one-third ounce of *Mikro-Quat to one gallon of water yields 235 ppm active quaternary.
3. The taste of ice and water will not be affected by the sanitizing of parts using the above mixed sanitizing solutions. Rinsing of parts is not required with this relatively mild solution, but air drying of the parts is suggested before reassembly.

2. Pour some of the sanitizing solution into the Bin drain.
3. Move both ON-OFF switches on the Control Box, to the ON position.
4. Replace all panels, etc., if any, not replaced at the end of the Cleaning procedure.
5. Clean and sanitize the interior bin and surfaces each week.

**Sterilex 3-Q sanitizing tablets are distributed by Pittsburgh Chemical Laboratory, Inc., Pittsburgh, PA 15222, and may be obtained through most restaurant supply houses.*

**Mikro-Quat, is manufactured by Economics Laboratory, Inc., Osborn Building, St. Paul, MN 55102, and may be obtained from them through their Magnus Division, The Klenzade division, or from restaurant supply houses.*

SECTION VI SERVICE DIAGNOSIS

The Service Diagnosis Section is for use in aiding the serviceman in diagnosing a particular problem for pin-pointing the area in which the problem lies, thus an ever available reference for proper corrective action.

The following charts list corrective actions for the causes of known symptoms of certain problems that can occur in the Icemaking-Refrigeration System.

I. ICEMAKING - REFRIGERATION SYSTEM

SYMPTOM	POSSIBLE CAUSE	CORRECTION
Irregular size cubes and some cloudy.	Some jets plugged. Shortage of water. Unit not level. Water overflowing vent holes on low side, burning cubes.	Clean jets. See Shortage of water CORRECTION. Level cabinet, as required.
Cubes too large.	Cube Size Control set too cold.	Rotate Cube Size Control dial toward WARMER.
Cubes too small.	Cube Size Control set too warm. Partially restricted capillary tube. Moisture in system. Shortage of water. Loss of refrigerant.	Rotate Cube Size Control dial toward COLDER. Blow refrigerant charge; replace drier; evacuate system; add refrigerant charge. Same as above CORRECTION. See Shortage of water CORRECTION. Check for refrigerant leaks, correct leaks; recharge system.
Cloudy Cubes.	Shortage of water. Dirty water supply. Accumulated impurities.	See Shortage of water SYMPTOM. Install water filter or softener. Use SCOTSMAN Ice Machine Cleaner.
Shortage of water.	Water spraying out through curtain. Water solenoid not opening. Water leak in sump area. Partial restrictions in water strainer.	Hang curtain in proper position. Repair or replace solenoid. Locate leak and repair or correct condition. Clean or replace strainer.
Shortage of water in upper freezing chamber.	Defective lower seal in upper freezing chamber.	Replace lower seal.

SYMPTOM	POSSIBLE CAUSE	CORRECTION
Decreased ice capacity.	Defective compressor. Leaky water valve. High head pressure, result of dirty condenser or faulty Fan Motor. Non-condensable gas in the system. Poor circulation or extreme hot location. Overcharge of refrigerant. Hot gas solenoid valve leaking. Partially restricted capillary tube.	Replace compressor. Repair or replace valve. Clean condenser. Repair or replace Fan Motor. Purge the system. Relocate the cabinet; or provide ventilation by cutting openings. Slowly purge off to correct charge. Replace valve. See Cubes too small CORRECTION.
Poor harvests.	Too short defrost time. Restriction in water inlet line. Hot gas solenoid does not open. Plugged air vent holes in upper part of cube cups.	Check and adjust harvest cycle. Check Timer two-minute setting. Check strainer and flow check valve. DO NOT remove flow control washers. Binds or burned out. Replace. Clean out air vent holes.
Icemaker does not harvest.	Water pressure too low.	Check for 20 PSI flowing water.
Compressor cycles intermittently.	Low voltage. Dirty condenser. Air circulation blocked. Defective Fan Motor. Non-condensable gases in system.	Check for circuit overload. Check building supply voltage, if low, contact power company. Clean condenser with vacuum cleaner or brush. DO NOT USE A WIRE BRUSH. Locate cabinet with adequate air space for proper air flow. Replace Fan Motor. Purge the system.
Icemaker will not operate.	Blown fuse in line. Master switch in OFF position. Faulty Master switch. Timer contacts open.	Replace fuse and check for cause. Set switch to ON position. Replace switch. Replace Timer microswitch.
Hole washed inside ice cube.	Water over the top of cube cups during harvest cycle.	Check and re-level the AC25 cabinet.